

White Paper  
**IEEE 1588 Precise Time Protocol: The New Standard in  
Time Synchronization**



## Overview—Precise Time and the Trouble with Ethernet

---

As network computing becomes more complex and the world becomes more interconnected, the need for more precise time synchronization has greatly increased. Network Time Protocol (NTP) and IRIG time code have been the most common protocols governing time transfer, but the recently developed IEEE 1588 Precise Time Protocol (PTP) now promises to revolutionize time synchronization by improving accuracy and reducing cost. While certain other precise sync protocols require significant investment in hardware and cabling, PTP makes highly precise timekeeping possible using the most widely deployed medium for network connectivity—Ethernet.

While Ethernet has proven to be a ubiquitous and inexpensive medium for connectivity, it has not been well-suited for applications requiring precise synchronization. By nature it is nondeterministic, which creates difficulty for real-time or time sensitive applications that require synchronization. On an NTP-based LAN, network devices and computer operating systems add latency and jitter that reduces synchronization accuracy to 1 millisecond to 2 milliseconds. Applications requiring greater accuracy have often had to deploy separate cabling systems and dedicated clocks—the IRIG B protocol, for instance, requires a dedicated system of coaxial cables to carry timing signals directly between IRIG B clocks separate from any data network.

PTP overcomes the Ethernet latency and jitter issues through hardware time stamping at the physical layer of the network. The result can be an unprecedented accuracy in the 10-nanosecond to 100-nanosecond range that is achieved using an Ethernet network to carry the timing packets, allowing for remarkable cost savings. This paper examines how PTP works, compares its effectiveness to other protocols, and explains why it is so cost effective.

## Choosing a Standard: NTP vs. IRIG vs. PTP

NTP has been the most common and arguably the most popular synchronization solution because it performs well over LANs and WANs and is relatively inexpensive to implement, requiring little in the way of hardware. And while NTP should be able to deliver accuracy of 1 millisecond to 2 milliseconds on a LAN or 1 millisecond to 20 milliseconds on a WAN, this is far from guaranteed network-wide. This is largely due to the use of switches and routers on LANs and WANs and the fact that many NTP clients run on non-real-time operating systems such as Windows or Linux, which were not designed for time keeping accuracy and therefore rarely deliver it. On Windows, for instance, one can often witness clock corrections of 10 milliseconds to 50 milliseconds because the system was busy performing tasks it deemed more important than timekeeping.

IRIG time code provides increased accuracy—up to 1 microsecond to 10 microseconds—and is often used where precision timing is mission critical: in military, aerospace, and power utility instrumentation. But improved accuracy comes at a cost. IRIG systems eschew Ethernet in favor of dedicated coaxial timing cabling between dedicated hardware clocks, which are not only an added expense, but create an extra burden on the physical infrastructure of the facility. PTP, on the other hand, offers the cost-effectiveness of NTP by using existing Ethernet LANs, and it exceeds the accuracy of the IRIG clocks. PTP can coexist with normal network traffic on a standard Ethernet LAN using regular hubs and switches, and yet provides synchronization accuracy to the sub-microsecond level. With the addition of IEEE 1588 boundary clocks or transparent switches, 20-nanosecond to 100-nanosecond synchronization accuracy is achievable. The key to this caliber of performance is hardware-assisted time stamping.

**Table 1 • Comparison of Synchronization Requirements of NTP, IRIG Time Code, and IEEE 1588**

Protocol	Sync Accuracy	Interconnect	Required Clock Hardware and Software
NTP	1 ms to 10 ms	Ethernet LAN or WAN	Hardware or software server, software clients
IRIG	1 $\mu$ s to 10 $\mu$ s	Coaxial cable	Hardware master and slaves
IEEE 1588	20 ns to 100 ns	Ethernet LAN	Hardware master and slaves

## How PTP Works: Hardware-Assisted Time Stamping

The two primary problems that must be overcome in network timekeeping are oscillator drift and time transfer latency. Regardless of the protocol used, oscillator drift can be mitigated by using higher quality oscillators and by deriving time from a more accurate source, such as GPS. The time transfer latency problem is more difficult and is two-fold in nature: there is latency associated with processing of time packets by the operating system, as well as network latency created by the hubs, switches, cables, and other hardware that exist between clocks. It is in the area of reducing operating system latency that PTP is most successful.

PTP combines time stamping units (TSU) with an innovative method for exchanging time stamp detail between master and slave clocks. A TSU placed between the Ethernet Media Access Control (MAC) and the Ethernet PHY transceiver sniffs both inbound and outbound traffic and issues a time stamp when the leading bits of a 1588 packet are identified, precisely marking the arrival or departure of 1588 time packets.

The following illustration shows hardware set up for a system deploying IEEE 1588. The time stamp unit monitors packets at the MII layer, between the Ethernet MAC and PHY, and issues a precise time stamp when a 1588 timing packet passes through it.

**Figure 1 • Hardware of IEEE 1588 System**

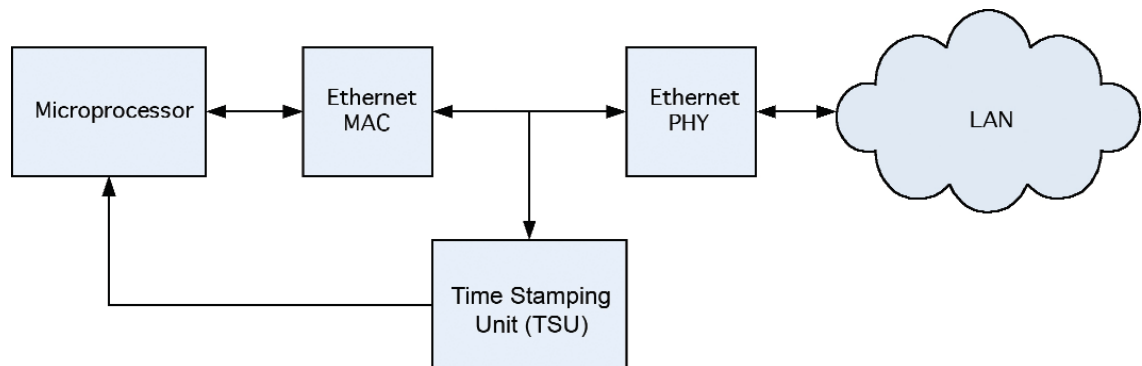

In order to estimate and mitigate operating system latency, the master clock periodically sends a Sync message based on its local clock to a slave clock on the network. The TSU marks the exact time the Sync message is sent, and a Follow\_Up message with the exact time information is immediately sent to the slave clock. The slave clock time stamps the arrival of the Sync message, compares the arrival time to the departure time provided in the Follow\_Up and is then able to identify the amount of latency in the operating system and adjust its clock accordingly.

Network-related latency is reduced by measuring the roundtrip delay between master and slave clock. The slave periodically sends a delay request message (Delay\_Req) to the master clock which issues a delay response message (Delay\_Resp). Since both messages are precisely time-stamped, the slave clock can combine this information with the detail from the Sync and Follow\_Up messages to gauge and adjust for network-induced latency. The protocol for exchanging precise time stamps is detailed in the the following illustration.

**Figure 2 • Packet Transfer Sequence from Master to Slave**

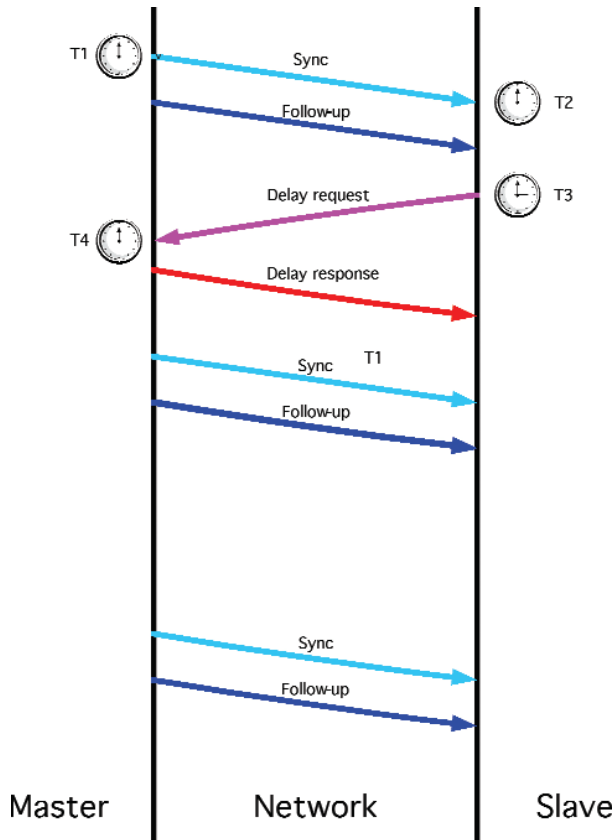

The sequence of packets is used to transfer time from the 1588 master to a 1588 slave. Sync packets are stamped as they leave the master (T1) and arrive at the slave (T2). Follow-up packets communicate the sync packet departure time to the slave. Delay response packets are stamped as they leave the slave (T3) and when they arrive at the master (T4). Sync and follow-up packet pairs are sent by the master on a periodic basis, as are the delay request and delay response packets. The formula for slave clock correction=  $0.5 (T1 - T2 - T3 + T4)$ .

## Determining Target Accuracy

---

The following sections describe how to determine target accuracy.

### Choosing Broadcast Intervals and Oscillator Types

In PTP, the desired accuracy of timing determines how often sync messages are broadcast and what kind of oscillator is used. More frequent broadcasts result in more accurate sync, but also in more network traffic, although the bandwidth used is extremely small. Higher quality oscillators also result in more accurate sync. It may be tempting to try to achieve target accuracy more economically by using a lower quality oscillator while increasing broadcast frequency, but this is inadvisable. Low-quality oscillators lack the stability needed to achieve high precision with PTP, so shortening the broadcast interval offers diminishing returns.

Accuracy is also a function of the IEEE 1588 master clock, called the grandmaster, which is the ultimate source of time on the network. Grandmasters are typically referenced to GPS so that they are both very stable and very accurate. Accuracy to UTC, TAI, or GPS is typically 30 nanoseconds RMS or better. By starting with such an accurate clock with an absolute time reference, time on a PTP-enabled network can be very well synchronized. A quality grandmaster also provides other measurement features to characterize the latency and jitter characteristics of network elements and to measure slave accuracy relative to the grandmaster. Ironically, a quality grandmaster clock also supports NTP and IRIG timing requirements. This makes sense as there are legacy systems in place that will need synchronization as well as new PTP deployments.

### Selecting Other Hardware

PTP has been readily implemented to work on Ethernet LANs where router buffer delay and switch latencies undermine the accuracy of time transfer. Consequently, the other variables in achieving target time transfer accuracy are the use of hubs versus switches, boundary clocks, or transparent clocks.

When evaluating cost versus packet delay, hubs are generally considered the best value. Switches may move packets more efficiently, but reduce accuracy because of packet jitter.

The boundary clock is a multi-port switch containing one port that is a PTP slave to a master clock, while the other ports are masters to downstream slave clocks. Boundary clocks provide a decent method for regulating time to a number of subnets. But using cascading boundary clocks accumulates non-linear time offsets in their servo loops, resulting in unacceptable degradation of accuracy.

The transparent clock is another potential hardware option for the PTP-based network. This is a PTP-enhanced switch which modifies the precise time stamps in the Delay\_Resp and Follow-Up messages to account for receive and transmit delays within the switch itself. The result is improved sync between slave and master clocks. But the transparent clock can also create security issues when the original packet crypto checksum doesn't match the final packet arriving at the slave.

The following histogram shows the precision of time synchronization between IEEE 1588 master and slave using three different kinds of Ethernet connection devices. Inconsistent device latency and jitter results in increased clock offset errors represented by the increased dispersion in the data.

Figure 3 • Overlaid Histograms Relative to Device Type

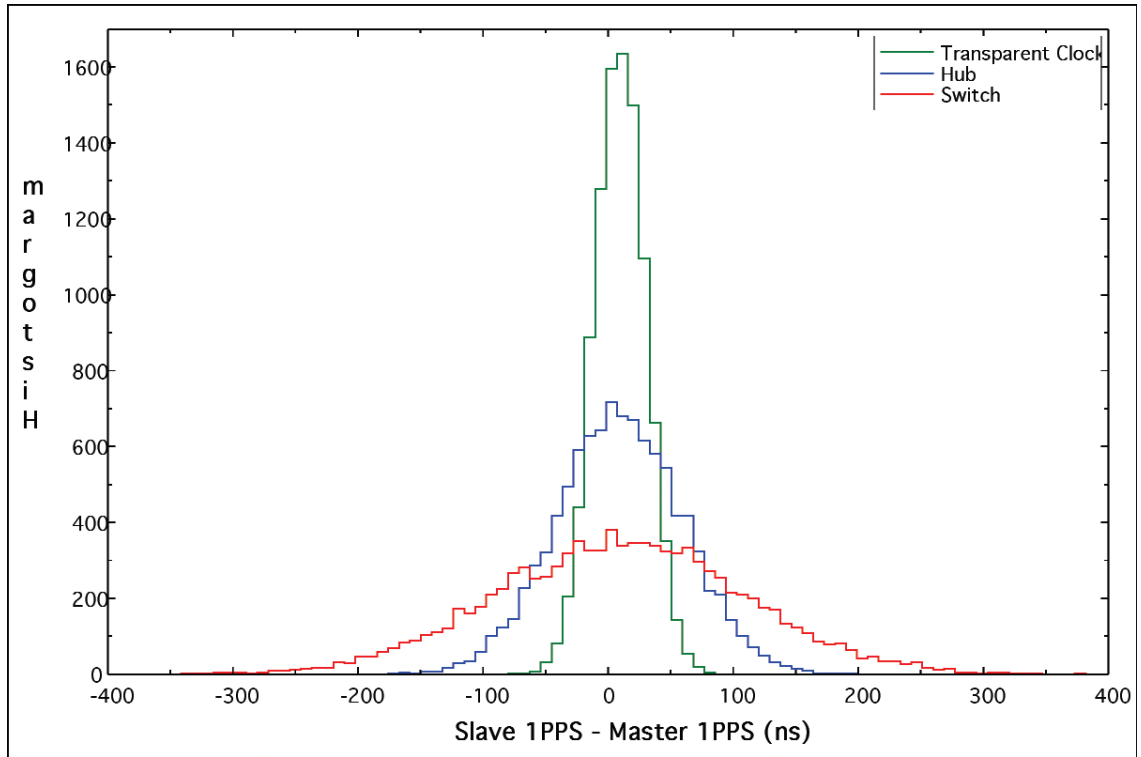

## Enabling Cost-Effective Real-Time Applications

---

In addition to extraordinary accuracy, PTP also facilitates the operation of real-time or near real-time data acquisition systems over Ethernet. Traditionally, these systems have depended upon triggering techniques and delay compensation independent of the data network in order to coordinate synchronized data collection. But PTP eliminates the necessity—and the cost—of such measures.

Consider the example of a real-time control system that is set up over Ethernet with a variety of independent sensors. Each sensor uses an onboard 1588 clock slaved to a grandmaster clock and is synchronized with the other sensors on the network to an accuracy of 1 microsecond. Every 5 milliseconds, each sensor takes a measurement and sends the information back to the controller, using the same LAN that is coordinating the synchronization of the sensors. The result: data is acquired synchronously from the entire system at precise intervals, without using triggering techniques or delay compensation. There is no trigger variation caused by trigger propagation delay between the near and far sensors. Because the 1588 modules are relatively inexpensive and can easily be added to the Ethernet-based network, the system allows for cost-effective real-time or near-real data acquisition.

### PTP and Military and Aerospace Applications

Because of its precision, cost-effectiveness, and ease-of-use, PTP can be expected to be widely used in military and aerospace applications. Systems that are deployed in military theater situations to identify enemy threats can be constructed from ad hoc Ethernet networks that connect a variety of sensors. Sonar systems in submarines can improve acoustic intercept and ranging accuracy by deploying PTP time stamp technology close to the sensors. Additionally, PTP is replacing IRIG systems in aircraft flight test because it provides tighter sync and eliminates the need for additional cabling.



## The Future of PTP

---

PTP has justifiably received considerable attention since its introduction in 2002, and its influence is growing. A variety of vendors are producing hardware that supports PTP, including Intel, which has recently embedded an IEEE 1588 TSU into one of its networking microprocessors. The next version of the 1588 protocol is currently being defined and is expected to increase accuracy even more. And improved fault tolerance and compatibility with SNMP are expected to enhance PTP interoperability with existing network infrastructure. With its nanosecond accuracy, ease-of-deployment, and cost-effectiveness, PTP is poised to transform the landscape of time-synchronized applications in any number of fields.

To learn more about IEEE 1588, visit <http://ieee1588.nist.gov/>

Some applications require the time-of-day (TOD) be the same as other devices, called synchronization. Other applications require that there be a precise frequency between two or more devices, called syntonization. The means by which these are most commonly achieved in applications are as follows.

**Table 2 • Synchronization vs. Syntonization (Time vs. Frequency)**

Time Transfer Mechanism	Synchronization	Syntonization
GPS	Best	Best
IEEE 1588	Best	Best
IRIG	Better	
NTP	Good	

**Microsemi Corporate Headquarters**

One Enterprise, Aliso Viejo,  
 CA 92656 USA  
 Within the USA: +1 (800) 713-4113  
 Outside the USA: +1 (949) 380-6100  
 Fax: +1 (949) 215-4996  
 Email: [sales.support@microsemi.com](mailto:sales.support@microsemi.com)  
[www.microsemi.com](http://www.microsemi.com)

© 2005–2017 Microsemi Corporation. All rights reserved. Microsemi and the Microsemi logo are trademarks of Microsemi Corporation. All other trademarks and service marks are the property of their respective owners.

Microsemi makes no warranty, representation, or guarantee regarding the information contained herein or the suitability of its products and services for any particular purpose, nor does Microsemi assume any liability whatsoever arising out of the application or use of any product or circuit. The products sold hereunder and any other products sold by Microsemi have been subject to limited testing and should not be used in conjunction with mission-critical equipment or applications. Any performance specifications are believed to be reliable but are not verified, and Buyer must conduct and complete all performance and other testing of the products, alone and together with, or installed in, any end-products. Buyer shall not rely on any data and performance specifications or parameters provided by Microsemi. It is the Buyer's responsibility to independently determine suitability of any products and to test and verify the same. The information provided by Microsemi hereunder is provided "as is, where is" and with all faults, and the entire risk associated with such information is entirely with the Buyer. Microsemi does not grant, explicitly or implicitly, to any party any patent rights, licenses, or any other IP rights, whether with regard to such information itself or anything described by such information. Information provided in this document is proprietary to Microsemi, and Microsemi reserves the right to make any changes to the information in this document or to any products and services at any time without notice.

Microsemi Corporation (Nasdaq: MSCC) offers a comprehensive portfolio of semiconductor and system solutions for aerospace & defense, communications, data center and industrial markets. Products include high-performance and radiation-hardened analog mixed-signal integrated circuits, FPGAs, SoCs and ASICs; power management products; timing and synchronization devices and precise time solutions, setting the world's standard for time; voice processing devices; RF solutions; discrete components; enterprise storage and communication solutions; security technologies and scalable anti-tamper products; Ethernet solutions; Power-over-Ethernet ICs and midspans; as well as custom design capabilities and services. Microsemi is headquartered in Aliso Viejo, California, and has approximately 4,800 employees globally. Learn more at [www.microsemi.com](http://www.microsemi.com).

MSCC-0104-WP-01007-1.00-1117